

## Static Concrete pump

## BSA 2110HD

Output up to 110m<sup>3</sup>/h  
Delivery Pressure up to 220 bar

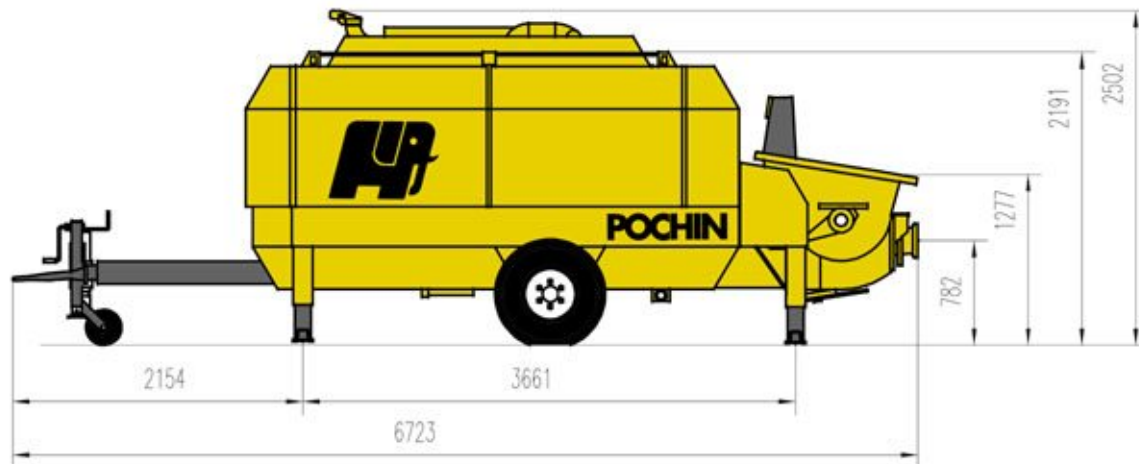

### Technical data for concrete pump

<b>Model</b>	<b>BSA 2110 H-D</b>	
Part number	AN 101113.003	
Output	110 / 76 * m <sup>3</sup> /h	
Delivery pressure	150 / 220 * bar	
Delivery cylinder ∅	200 mm	
Delivery cylinder stroke	2100 mm	
Stroke volume 2 cyl.	131.8 l	
Strokes / minute	28 / 19*	25 / 17*
Hydraulic ratio 1:	3 / 2*	
Engine/motor power	240 kW	160 kW / 50 Hz
Hopper	RS 900H	
Capacity	approx. 600 l	
Filling height	approx. 1.3 m	
Transfer tube	S 2015 D	
Pressure connection	6"	
Control system	Free-Flow Hydraulics	
Weight	7000 kg	7000 kg

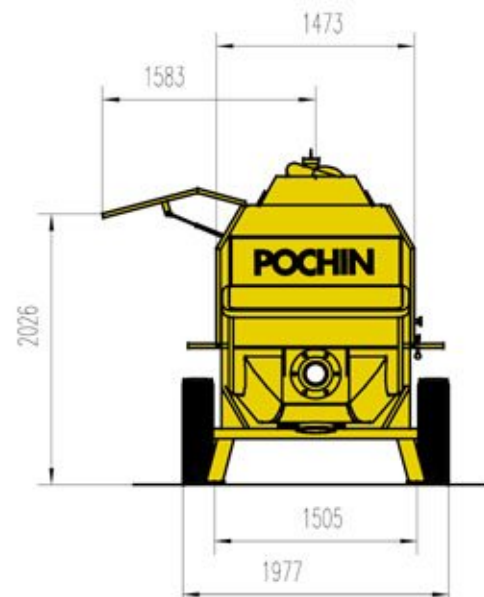

# Static Concrete Pump

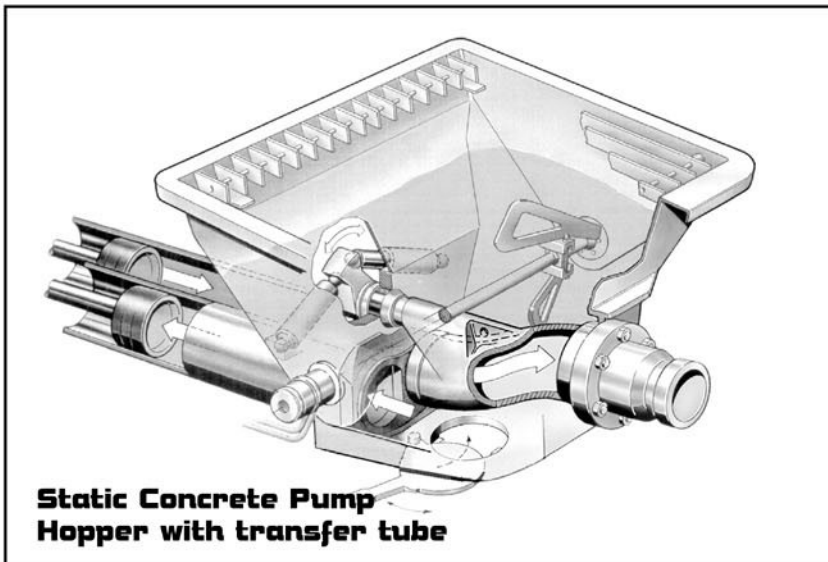
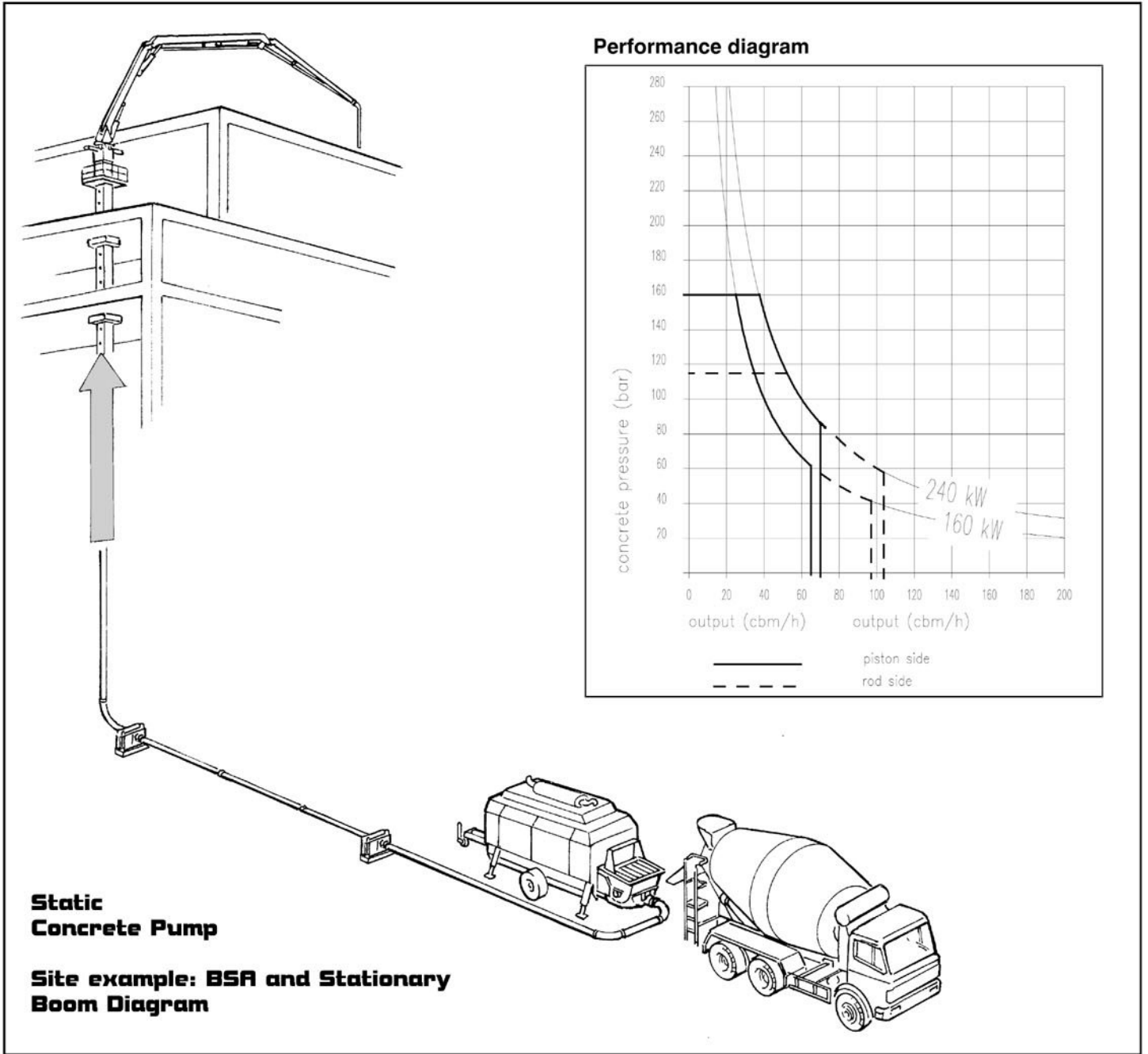

Head Office. Brooks Lane, Middlewich, Cheshire CW10 0JQ

Tel: **01606 833333** Fax: **01606 836027**

Email: [pumping@pochins.plc.uk](mailto:pumping@pochins.plc.uk)

Web Site: [www.pochins.co.uk](http://www.pochins.co.uk)